

Grade : VI

Subject : Science

LIGHT

Emission of Light

Classifying objects on the basis of emission of light.

Luminous objects

- Objects that emit their own light.
- Example: Sun, Electric torch, firefly, etc

Non-luminous

- Objects that do not emit their own light but are visible due to light falling on them.
- Example: moon, chair, table, etc.

Transparent

- Objects or materials through which light can pass totally.
- Example : glass, water, air, etc.,

Translucent

- Objects that allow light to pass through them partially.
- Example : butter paper, tissue paper, tec.

Opaque

- Object that do not allow light to pass through them.
- Example; book, brick, etc.

Shadow

- Region without light that forms behind an object kept in the path of light.
- Opaque objects cast a dark shadow.
- Translucent objects produce a weak shadow.
- Transparent objects do not cast a shadow at all.
- Shadow is formed in the opposite direction to the source of light and behind the objects.
- Length of the shadow changes according to the position of the source of light with respect to the object.
- Colour of the shadow always stays black.

Eclipse

Solar eclipse

- The moon comes between the sun and the earth, so that the earth (in the shadow) darkens during the day.
- Since the sun is large, this shadow has an umbra and a penumbra.
- In the umbra, the sun is totally blocked and a total eclipse is seen.
- In the penumbra, a partial eclipse is seen.

Lunar eclipse

- The moon and the sun are in a straight line such that the earth is in between the sun and the moon, the shadow of the earth falls on moon and the moon cannot be seen.
- Partial lunar eclipse – only a part of moon is visible and the part of moon that falls under the umbra of the earth is not visible.
- In lunar eclipse whole moon is in the umbra of the earth.

Due to Smaller Light source

- Only one dark shadow is formed.
- This is known as umbra.

Due to Smaller Light source

- Two shadows are formed-a dark one in the centre and a light one on the outside.
- Dark shadow is called umbra and the faint or lighter shadow is called penumbra.



I. Know the Terms

- **Solar eclipse:** Shadow cast by the moon on the earth.
- **Lunar eclipse:** Shadow cast by the earth on the moon.

Objective Type Questions

(1 Mark each)

I. Multiple choice questions

- The light is passed through object 'A' then 'A' is
a. Translucent b. Opaque c. Transparent d. None of these
- Which one is the natural source of light?
a. Tube light b. Electric bulb c. Sun d. None of these
- The shape of the shadow depends upon the
a. Size of the object b. Position of source of light
c. Size of source of light d. Shape of the object
- The light ray which returns after striking a smooth surface is called.
a. Incident ray b. Normal ray c. Reflected ray d. None of these
- Glass sheet is a
a. Transparent object b. Translucent object
c. Opaque object d. All of these
- Stars are
a. Luminous b. Non-luminous c. Both of these d. None of these
- The objects which allow the most of the light to pass are called.
a. Translucent b. Opaque c. Transparent d. None of these
- Which of the following is a luminous object?
a. Sun b. Table c. Chair d. Pencil
- Which of the following is a non-luminous object?
a. Sun b. Lamp c. Eraser d. Tube light
- Shadows give us information about.
a. Shape of source b. Shape of object c. Surface d. Size of object

11. Natural luminous object among the following is
 a. Tube light b. Bulb c. Moon d. Stars
12. According to emission of light number of types of objects is
 a. One b. Two c. Three d. Four
13. On the basis of passage of light, objects are classified into
 a. Four types b. Five types c. Three types d. None
14. Non-luminous objects among the following are
 a. Table b. Glass c. Both (a) and (b) d. None of these
15. Shadow of an object is seen in
 a. Blue b. Red c. Black d. None

1. c	2. c	3. d	4. c	5. a	6. a	7. c	8. a
9. c	10. b	11. d	12. b	13. c	14. d	15. c	

II. Multiple choice questions

1. In lateral inversion :
 (a) Image is upside down (b) Image bends laterally
 (c) Left of an object appears right of the image (d) Image gets inverted
2. By which device you can see image of sun ?
 (a) Telescope (b) Periscope (c) Pinhole camera (d) Plane mirror
3. The process of returning back of light ray from a shining surface is called :
 (a) Reflection (b) Refraction (c) Inversion (d) Lateral inversion
4. The image formed in water is :
 (a) Erect (b) Diminished (c) Inverted (d) Enlarged
5. The shape of shadow depends upon the :
 (a) Size of the object (b) Size of light source
 (c) Shape of object (d) Position of light source
6. Which of the rays of light is virtual ?
 (a) Incident ray (b) Reflected ray (c) Refracted ray (d) Normal ray
7. Image formed by a pinhole camera is :
 (a) Inverted (b) Erect (c) Laterally inverted (d) Black and white

8. Image formed by a plane mirror is :

- (a) Erect
- (b) Inverted
- (c) Erect but laterally inverted
- (d) None of these

9. Shadow of a red object will be :

- (a) Red
- (b) White
- (c) Yellow
- (d) Black

10. Image of sun through a pinhole camera can be seen as :

- (a) Long
- (b) Cylindrical
- (c) Circular
- (d) Any of these

11. Objects that emit or give out their own light are called :

- (a) Non-luminous objects
- (b) Opaque objects
- (c) Luminous objects
- (d) Translucent objects

12. The phenomenon taking place in the figure given below is called :

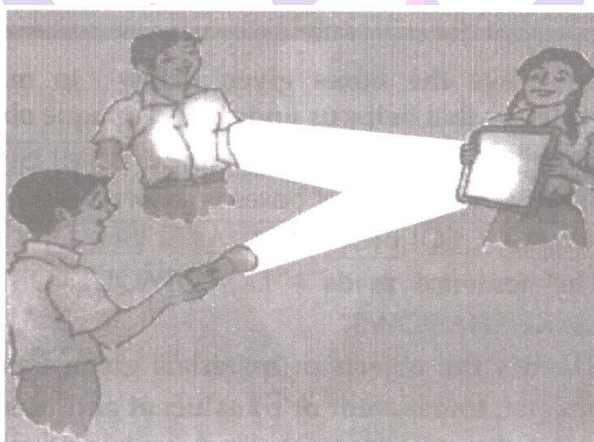

- (a) Shadow formation
- (b) Reflection of light
- (c) Both shadow formation and Reflection of light
- (d) None of these

13. Which of these is/are required to form the shadow of a ball ?

- (a) Torch
- (b) Ball
- (c) Screen
- (d) All of these

14. You will see the shortest shadow of yourself sunlight

- (a) in the morning
- (b) at noon
- (c) in the evening
- (d) in the night

15. Observe the picture given in Fig. carefully.

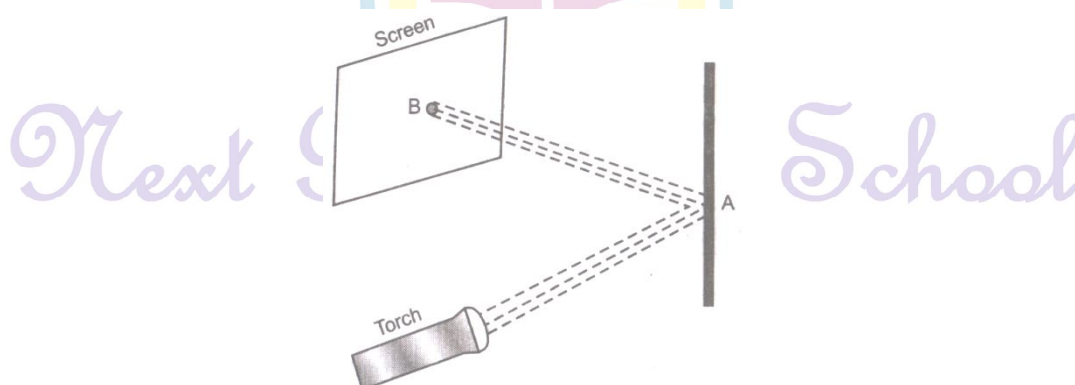

A patch of light is obtained at B, when the torch is lighted as shown. Which of the following is kept at position A to get this patch of light ? [NCERT Exemplar]

- (a) A wooden board (b) A glass sheet (c) A mirror (d) A sheet of white paper

16.

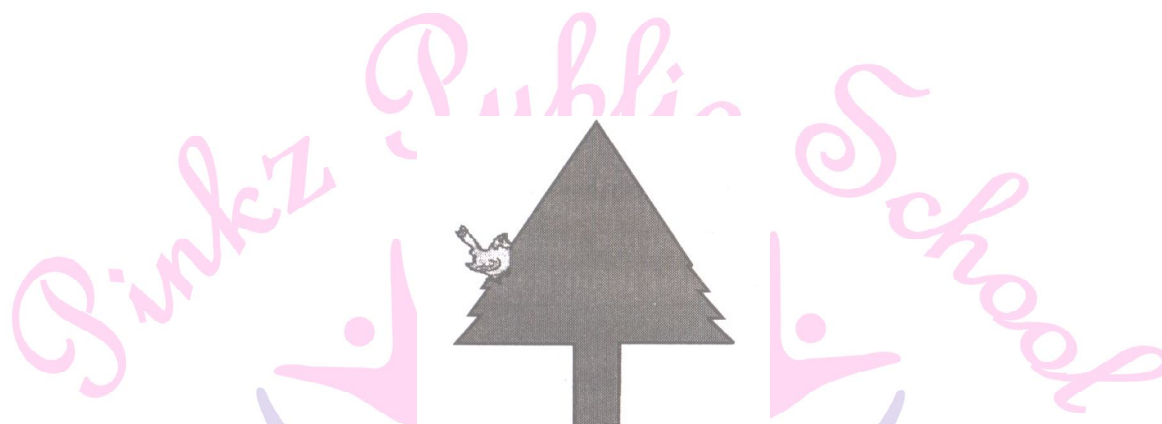

A student observes a tree given in above Fig. through a pin hole camera. Which of the diagrams given in Fig. (a) to (d) depicts the image seen by her correctly ? [NCERT Exemplar]

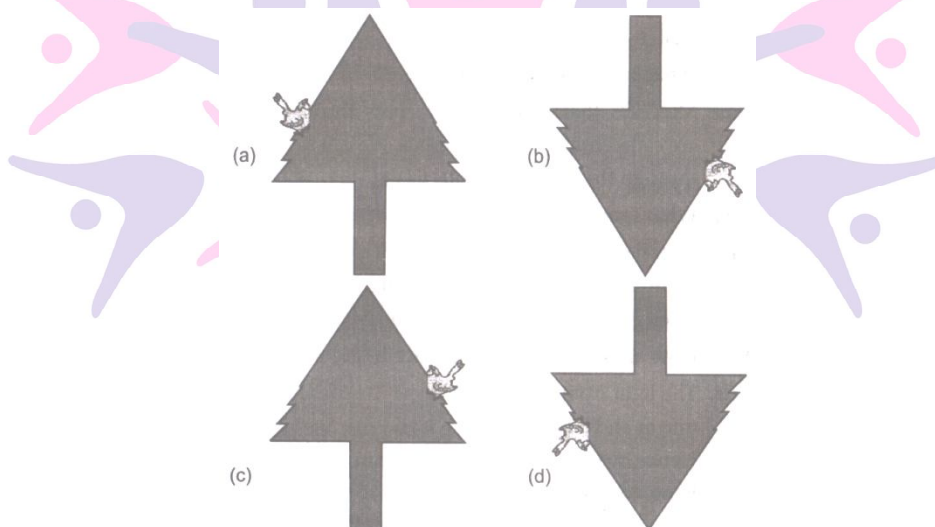

17. Four students A, B, C and D looked through pipes of different shapes to see a candle flame as shown in fig.

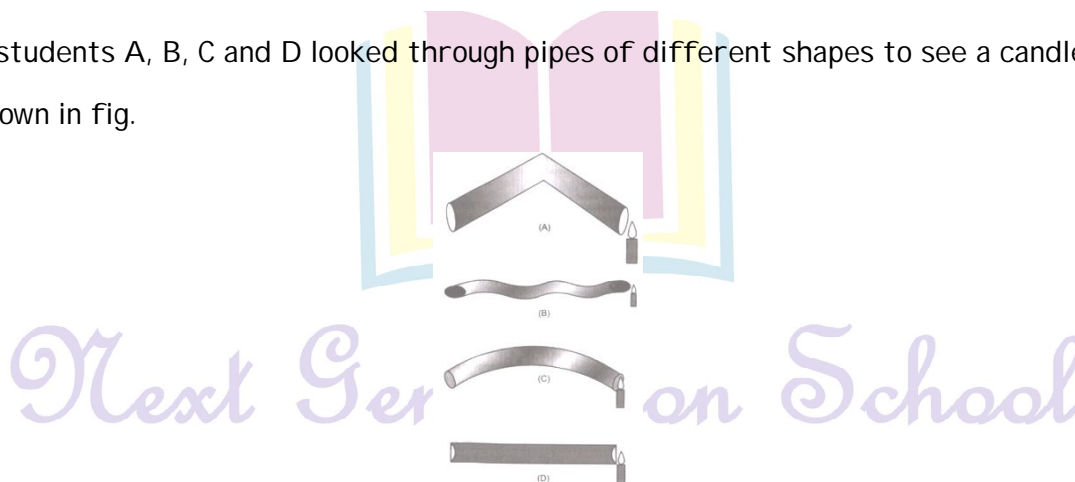

Who will be able to see the candle flame clearly ? [NCERT Exemplar]

- (a) A (b) B (c) C (d) D

18. Which of the following is not always necessary to observe a shadow ? **[NCERT Exemplar]**
 (a) Sun (b) Screen (c) Source of light (d) Opaque object

19. Paheli observed the shadow of a tree at 8 : 00 a.m., 12 : 00 noon and 3 : 00 p.m. Which of the following statements is closest to her observation about the shape and size of the shadow? **[NCERT Exemplar]**

- (a) The shape of the shadow of the tree changes but the size remains the same.
- (b) The size of shadow of the tree changes but the shape remains the same.
- (c) Both the size and shape of the shadow of the tree change.
- (d) Neither the shape nor the size of the shadow changes.

20. Which of the following can never form a circular shadow ?

- (a) A ball (b) A flat disc (c) A shoe box (d) An ice cream cone

21. Two students while sitting across a table looked down onto its top surface. They noticed that they could see their own and each other's image. The table top is likely to be made of.

- (a) Unpolished wood (b) Red stone
- (c) Glass sheet (d) Wood top covered with cloth

1. c	2. c	3. a	4. a	5. c	6. d	7. a	8. c	9. d	10. c	11. c
12. b	13. d	14. b	15. c	16. d	17. d	18. a	19. c	20. c	21. c	

I. Match the following

I) Column I	Column II
a. Jugnu	i. Reflects the light
b. Light	ii. Forms images of object
c. Mirror	iii. Travels in straight line
d. Pinhole camera	iv. Non-luminous
e. Moon	v. A luminous source

a. v	b. iii	c. i	d. ii	e. iv
------	--------	------	-------	-------

II) Column I	Column II
a. Umbra	i. Lunar eclipse on Moon
b. Penumbra	ii. Region of total darkness
c. Shadow of the Earth	iii. Luminous source
d. Shadow of Moon	iv. Region of partial darkness
e. Burning candle	v. Solar eclipse on the Earth

a. ii	b. iv	c. i	d. v	e. iii
-------	-------	------	------	--------

II. Match the following

I) Column A	Column B
a. The sun	i. Light and an opaque object
b. Objects through which we cannot see clearly	ii. Travels in straight line
c. Shadows	iii. Changes direction of light
d. Light	iv. Opaque
e. Mirror	v. Luminous

a. v	b. iv	c. i	d. ii	e. iii
------	-------	------	-------	--------

I. Fill in the blanks

- We can not see a _____ object in the dark.
- Light travels in a _____ line.
- Translucent objects block the light _____.
- _____ objects allow light to pass through them.
- Image formed in a pinhole camera is always _____.
- A shadow is formed when light falls on a / an _____ object.

1. non-luminous	2. straight	3. partially	4. Transparent	5. inverted	6. opaque
-----------------	-------------	--------------	----------------	-------------	-----------

II. Fill in the blanks

1. Glass is _____ but plastic is _____.
2. The sun is a _____ body.
3. The image formed by a mirror is due to _____.
4. The umbra is the _____ portion of the shadow.
5. Light helps us to _____ objects.
5. Objects that emit light of their own are called _____ object.
7. Objects like eraser, plastic scale, pen, pencil, cloth are called _____.
8. The shadow can be seen only on a _____.
9. The shadow of an object is _____ in colour.
10. Never ever look _____ at the sun.
11. A mirror _____ a beam of light.
12. Images are _____ from shadows.
13. Mirror reflection gives us _____ images.
14. Shadows are formed when an _____ object come in the path of light.

1. transparent, opaque	2. luminous	3. reflection of light	4. darkest
5. see	luminous	7. non-luminous	8. screen
9. black	10. directly	11. reflects	12. different
13. clear	14. opaque		

I. True or False

1. Black thick paper is translucent.
2. The partial shadow is called penumbra.
3. Moon is a luminous body.
4. Light travels in a straight line.
5. The shadow of a coloured object is also coloured.
6. Image formed by pinhole camera is erect.
7. Chair is a luminous object.
8. Opaque objects allow light to pass through them.
9. A mirror reflects a beam of light.

10. Mirror does not change the direction of light that falls on it.
11. Images are very different from shadows.
12. Shadow is formed when a transparent object comes in the path of light.
13. Light travels in curved line.
14. Glass is a transparent object but plastic is a luminous object.
15. Light travels in the form of rectilinear propagation.
16. The image of a red rose and a yellow rose is black in colour.

1. False	2. True	3. False	4. True	5. False	6. False	7. False	8. False
9. True	10. False	11. True	12. False	13. False	14. False	15. True	16. True

II. True or False

1. What are luminous objects?
2. What you will can an object which partially allows the light to pass?
3. What three things are necessary for the formation of shadow?
4. What is shadow?
5. What does formation of shadows prove about the nature of light?
6. Why should we not look directly at the Sun?
7. Are the images of coloured objects coloured?
8. What is reflection? Give an example.
9. Does the mirror change the direction of light?
10. Does pinhole camera form an erect image?

Answer:

1. Objects that give out or emit light of their own are called luminous object.
2. Translucent.
3. Source of light, an opaque object and a surface which can act as screen.
4. A dark figure / shade projected by a body intercepting light (rays of light).
5. Light rays move in a straight line.
6. Sun is very bright and radiates radiations that could be extremely harmful for the eyes.
7. Yes, the image of coloured is coloured similar to the object.
8. The act of rebound or throwing back is called reflection. Rebound of light of an object by a mirror to form the image of that object is called reflection.

9. Yes, a mirror changes the direction of light that falls on it.

10. No, a pinhole camera forms an inverted image.

NCERT Corner

Intext Questions

1. How do we see the objects around us?

We can see the objects around us with the help of light.

2. Can we see any object in a completely dark room?

No, we can not see any object in a completely dark room.

3. What type of objects a chair, a painting and a shoe are?

These are opaque objects.

4. Is the light from a far away object able to travel to our eyes through opaque objects?

No, light cannot pass through opaque objects.

5. What are shadows?

The dark patches formed on the ground, when light falls on the opaque objects, are called shadows.

6. What do we see on the ground, when sunlight falls on the opaque objects?

We see the shadows of opaque objects on the ground, when sunlight falls on these objects.

7. Do you observe your shadow in a dark room or at night when there is no light?

No, we cannot observe our shadow in a dark room or at night when there is no light.

8. Do you observe a shadow when there is just a source of light nothing else in a room?

No, we can not observe a shadow without any opaque object.

9. Name the things other than source of light and opaque object required to see the shadow.

Screen, like cardboard, wall etc.

10. Do the shadows look different in colour when the colours of the objects are different?

No, shadows are always same, i.e., black in colour.

11. Compare pinhole image with the shadow of some object.

The pinhole image is inverted whereas the shadow is different from it.

12. What property of light is responsible for the formation of shadows and pinhole image?

The light travels in a straight line path.

13. Through which pipe can we see the candle, straight pipe or curved pipe?

We can see the candle through a straight pipe because the light travels in a straight line.

Textbooks Questions

1. Rearrange the boxes given below to make a sentences that helps us understand opaque objects.

OWS	AKE	OPAQ	UEO	BJEC	TSM	SHAD
-----	-----	------	-----	------	-----	------

The rearrange of boxes is shown below.

OPAQ	UEO	BJEC	TSM	AKE	SHAD	OWS
------	-----	------	-----	-----	------	-----

The sentence reads - i.e., "OPAQUE OBJECTS MAKE SHADOWS".

2. Classify the objects or materials given below as opaque, transparent or translucent and luminous or non-luminous.

Air, water, a piece of rock, as sheet of aluminium, a mirror, a wooden board, a sheet of polythene, a CD, smoke, a sheet of plane glass, fog, a piece of red hot iron, an umbrella, a light fluorescent tube, a wall, a sheet of carbon paper, the flame of a gas burner, sheet of cellophane, a wire mesh, kerosene stone, sun, firefly, moon.

Classification of objects or materials is given below.

Object	Object is Transparent/ Translucent / Opaque	Object is Luminous / Non-luminous
Air	Transparent	Non-luminous
water	Transparent	Non-luminous
Piece of rock	Opaque	Non-luminous
Sheet of Aluminium	Opaque	Non-luminous
Mirror	Opaque	Non-luminous
Wooden board	Opaque	Non-luminous
Sheet of polythene	Transparent	Non-luminous
CD	Transparent	Non-luminous
Smoke	Transparent	Non-luminous

Sheet of plane glass	Transparent	Non-luminous
Fog	Transparent	Non-luminous

I. Very Short Answer Type Questions

1. Is the moon luminous or non-luminous body?

Moon is non-luminous body.

2. What is umbra?

Umbra is the dark region behind object facing light which does not receive light at all.

3. How does a light ray travel?

Light ray travels in a straight line.

4. Give one natural source of light.

Sun is a natural source of light.

5. What is shadow?

Shadow is the dark patches behind an opaque object where light does not reach.

6. What is penumbra?

The less darker shadow formed on the periphery of dark shadow is called penumbra.

7. Which types of surface produce clear images?

Polished and plane surface.

8. State the principle behind the working of a pinhole camera.

Light travels in straight line

9. What types of objects do not cast shadows?

Transparent object and few translucent objects do not cast shadows because light passes through them.

II. Very Short Answer Type Questions

1. Name a living luminous source of light.

Ans. Jugnu, firefly.

2. Can we form shadow with the help of light and an opaque object only ?

No, a screen is always needed.

3. When does lunar eclipse occur ?

When earth comes between sun and moon.

4. Why do we write in laterally inverted letters on ambulance ?

So that we can see it right in rear-view mirror.

5. Is shadow two dimensional or three dimensional ?

Two dimensional.

6. Can you form image in a transparent material ?

No, clear image cannot be formed.

7. What are translucent materials ?

Materials through which light can pass partially are called translucent materials. We cannot see clearly through them. For example : Wax paper.

8. What is light ?

Light is a source of energy. It cannot be seen but it enables us to see things.

9. What are transparent materials ?

Materials that allow light to pass through them are called transparent materials. We can see clearly through them. For example. Glass.

10. What is an opaque material ?

Materials that do not allow light to pass through them are called opaque materials. We cannot see through them. For example : Wood.

11. How are we able to see our face in the mirror ?

The light from the face strikes at the surface of the mirror and is reflected from it and reaches our eyes. Hence, we are able to see our face in the mirror.

12. How does light travel ?

Light travels in a straight line.

13. What is reflection ?

The bouncing off and change in direction of light on striking a plane mirror is called reflection.

14. You have 3 opaque strips with very small holes of different shapes as shown in Fig. If you obtain an image of the sun on a wall through these holes, will the image formed by these holes be the same or different ? [NCERT Exemplar]

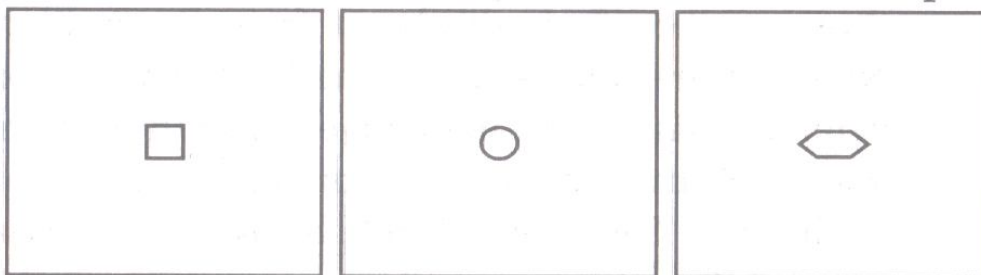

The image of the sun formed by these holes will be the same because the holes will act as pinhole cameras and light moves in straight line.

15. Observe the picture given in Fig. A sheet of some material is placed at position 'P', still the patch of light is obtained on the screen. What is the type of material of this sheet ? [NCERT Exemplar]

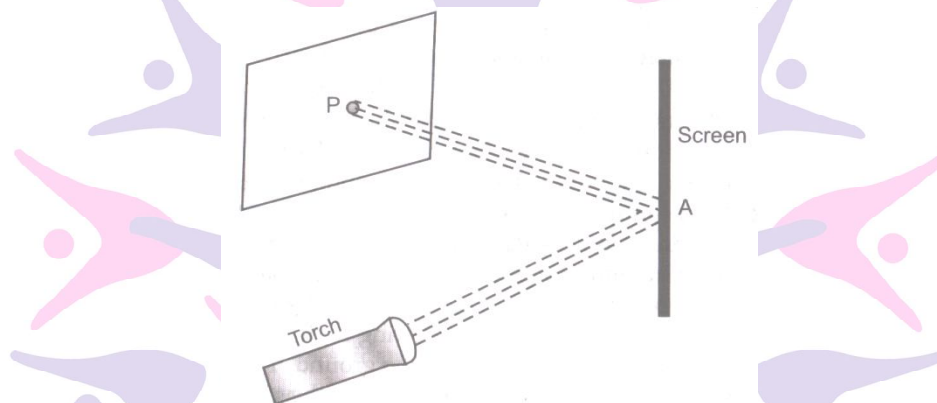

The material of this sheet is transparent glass Torch which allows the light to pass and the patch of light is obtained on screen.

16. Three torches A, B and C shown in Fig. are switched on one by one. The light from which of the torches will not form a shadow of the ball on the screen ?

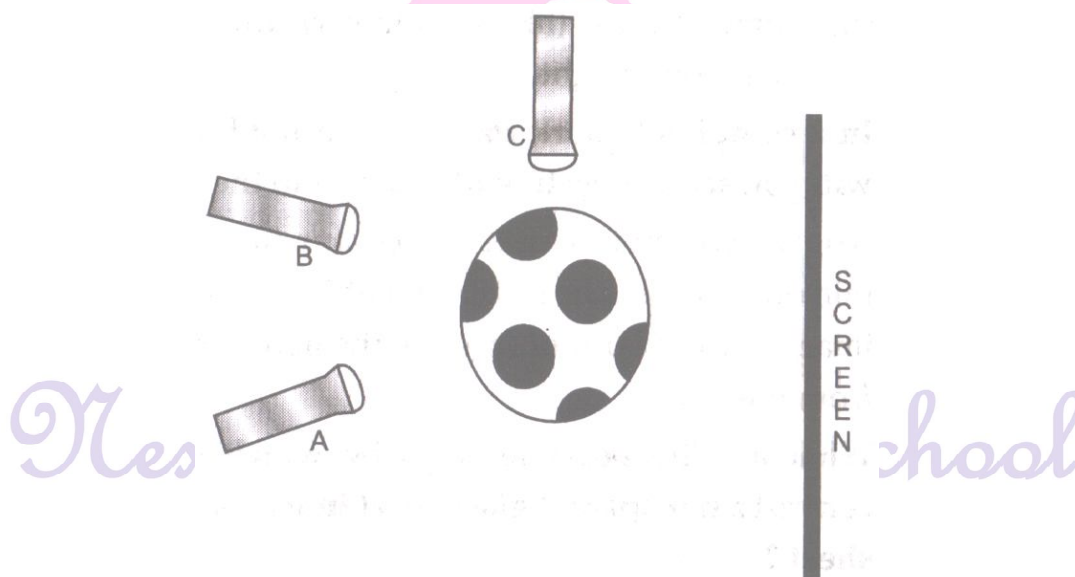

The light from the torch C will not form a shadow of the ball on the screen because the light travels in a straight line.

17. Look at the diagrams given in Fig.

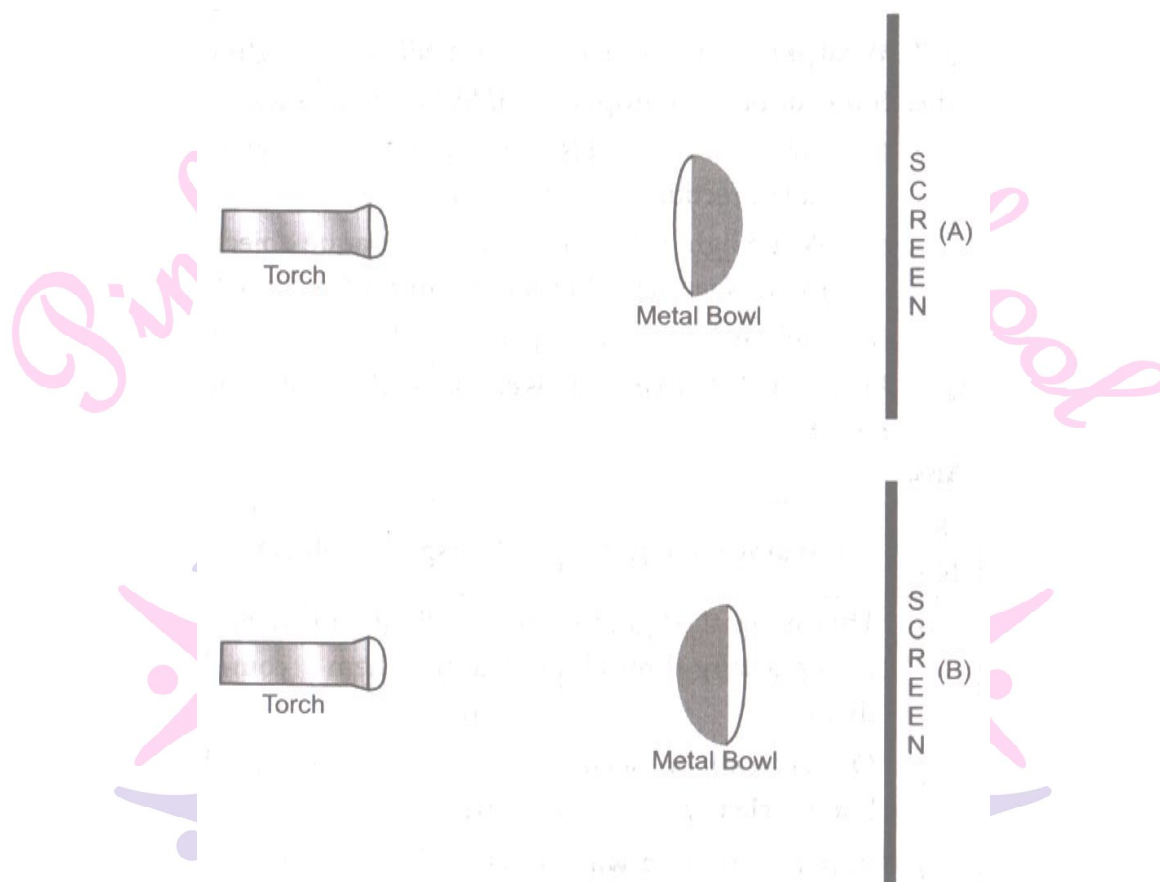

Will there be any difference in the shadows formed on the screen in A and B ?

[NCERT Exemplar]

No, there will not be any difference in the shadows formed on the screen in A and B due to same length and breadth of objects in both cases.

I. Short Answer Type Questions

1. We see moon shining in the sky, then why is it called non-luminous?

Moon shines because of sun's light falling on it.

2. What do you understand by incandescent body?

If we make a metal red hot, it emits light. This is called incandescent body.

3. What are the conditions for formation of shadow?

We need light source, opaque object and a screen.

4. Give two effects of light on plants.

The two effects of light on plants are.

- i. Plants use light for the preparation of their own food through the process of photosynthesis.
- ii. Some plants (like sunflower) turn in the direction of light.

5. In a completely dark room, if you hold a mirror, will you see a reflection of yourself in the mirror?

No, we will not be able to see our image in the mirror, as there is no source of light. We can see our image in the mirror only when the light is reflected from the mirror.

6. What are the possible ways by which you can convert a transparent glass sheet into a translucent sheet?

A transparent glass sheet can be converted into a translucent glass sheet by the following ways:

- i. By covering one side of the glass with butter paper.
- ii. by covering one side with a thin sheet of plastic.

7. What are the properties that are exhibited by light?

Some important properties of light are as follows.

- i. Light always travels in a straight line, which is called rectilinear propagation of light.
- ii. When light is obstructed by an opaque object, the a shadow of the objects is formed behind it.
- iii. Light exhibits the property of reflection.

8. Distance between transparent and translucent object.

S.No	Translucent object	Transparent object
a.	They allow the light to pass partially through them.	Allow light to pass through them completely.
b.	Objects can be seen, but not clearly.	Objects can be seen clearly.
c.	Butter paper and wax are examples of objects.	Glass and Air are examples of objects.

9. Show an experiment which proves that light always travels in a straight line.

The light always travels in a straight line. This can be shown by performing a simple activity. For this, first of all let us take three cardboards of equal size. Now, a hole is made at

the centre of each cardboard at the same level. The three cardboard are placed on a flat table and aligned linearly as shown in the figure. A candle is lighted at one end of the table with its flame at the level of the holes and is seen at the other end. It is observed that the light of the

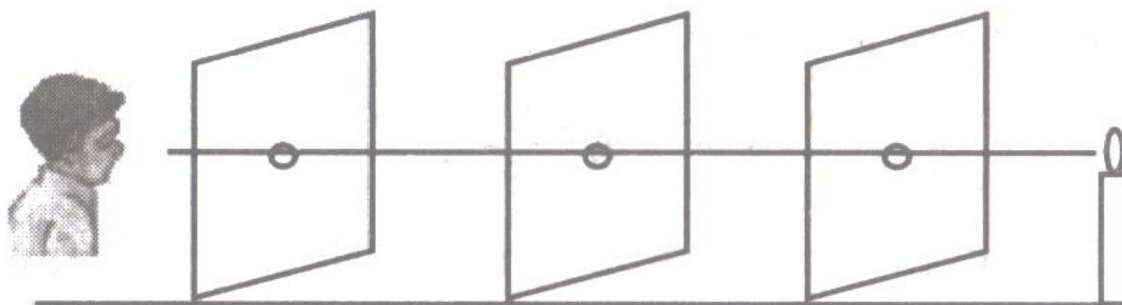

candle is seen effortlessly. Now, the middle one of the three cardboards is displaced from its position. Now, we are unable to see the light. The reason behind this is that the light travelling in the straight line is obstructed due to the misalignment of the cardboards. This proves that light always travels in a straight line.

10. Correct the following statements :

- (i) The colour of the shadow of an object depends on the colour of the object.
- (ii) Transparent objects allow light to pass through them partially.
- (i) The colour of the shadow of an objects does not depend on colour of the object.
- (ii) Transparent objects allow light to pass through them completely.

11. Suggest a situation where we obtain more than one shadow of an objects at a time.

[NCERT Exemplar]

We can obtain more than one shadow of an object at a time when we place the object in front of a mirror and put the light source behind the object.

12. On a sunny day, does a bird or an aeroplane flying high in the sky cast its shadow on the ground ? Under what circumstances can we see their shadow on the ground ?

[NCERT Exemplar]

No, a bird or an aeroplane flying high in the sky does not cast its shadow on the ground. They can cast shadow only when they are near the ground.

13. You are given a transparent glass sheet. Suggest any two ways to make it translucent without breaking it.

[NCERT Exemplar]

There are following ways to make transparent glass sheet translucent without breaking it : (i) By rubbing it on the ground and make it rough. (ii) By polishing it partially.

14. A torch is placed at two different positions A and B, one by one, as shown in Fig.

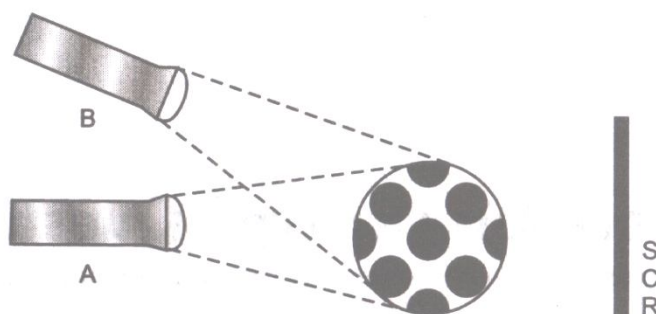

The shape of the shadow obtained in two positions is shown in Fig.

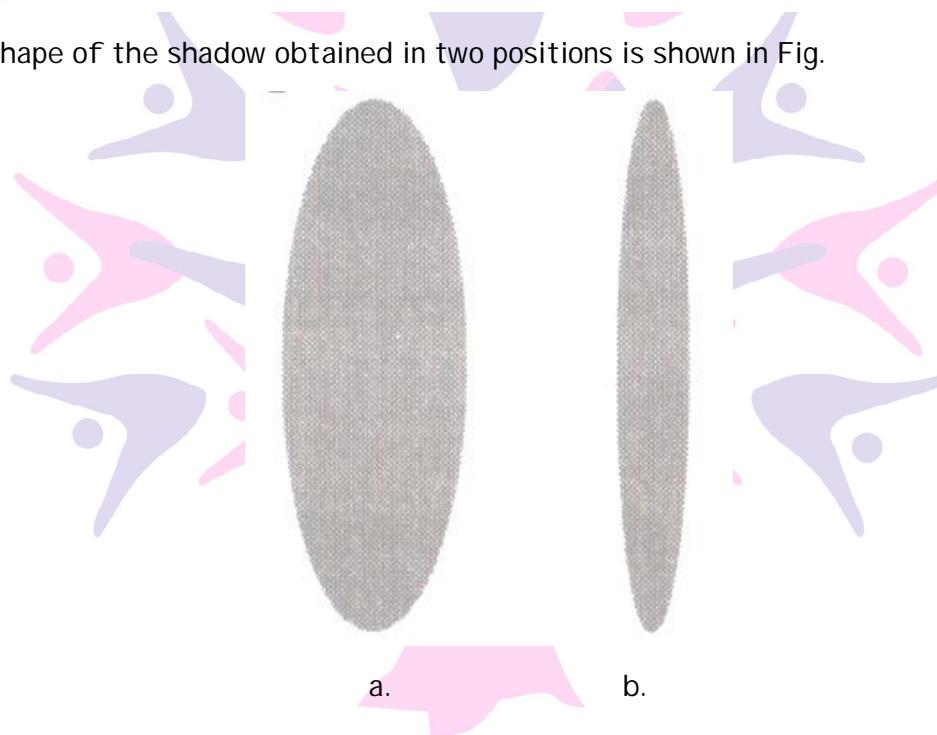

Match the position of the torch and shape of the shadow of the ball.

[NCERT Exemplar]

Position of torch A B

A

B

Shape of the shadow

a

b

15. A student covered a torch with red cellophane sheet to obtain red light. Using the red light she obtains a shadow of an opaque object. She repeats this activity with green and blue light. Will the colour of the light affect the shadow ? Explain.

[NCERT Exemplar]

The colour of the light will not affect the shadow because the amount of light will remain same. The shadow is affected by the shape of the object only.

16. Is air around us always transparent ? Discuss. [NCERT Exemplar]

Yes, air around us is always transparent because we can see the objects through air clearly.

17. Three identical towels of red, blue and green colour are hanging on a clothesline in the sun. What would be the colour of shadows of these towels? [NCERT Exemplar]

The colour of shadows of these towels will be black, because shadow does not change on changing the colour of an object.

18. Using a pinhole camera a student observes the image of two of his friends, standing in sunlight, wearing yellow and red shirt respectively. What will be the colour of the shirts in the image ? [NCERT Exemplar]

The colour of the shirts in the image will be the same. We see them on the screen because the pinhole camera forms the images having same - colours as the objects but upside down. Hence, yellow image is formed for yellow shirt and red, image in formed for red shirt.

19. In Fig. a flower made of thick coloured paper has been pasted on the transparent glass sheet. What will be the shape and colour of shadow seen on the screen ?

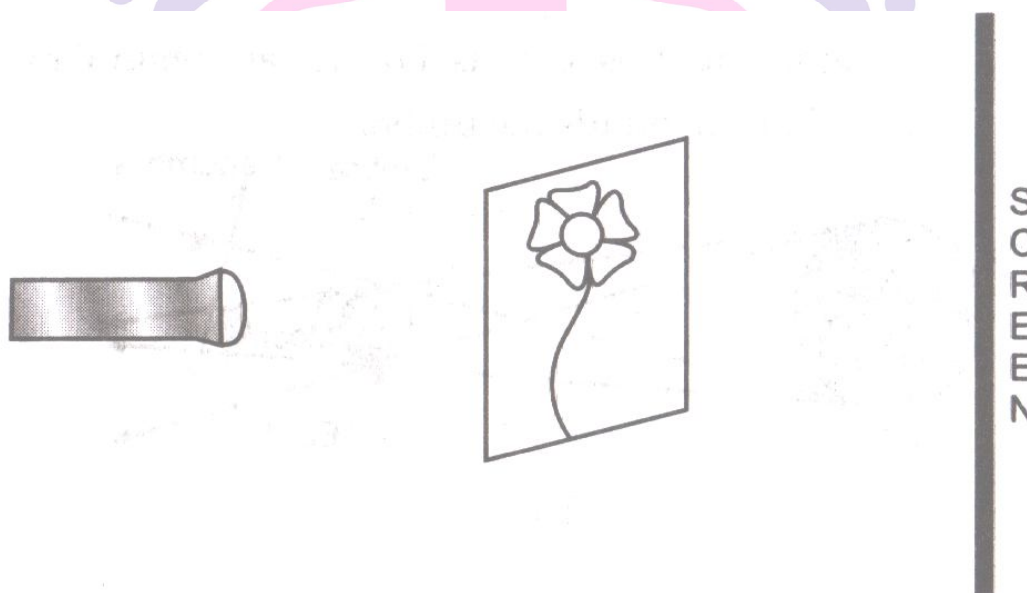

Next Generation School [NCERT Exemplar]

The shape of the shadow will be same as that of the flower and colour of shadow is black.

II. Short Answer Type Questions

1. State difference between a luminous and a non-luminous body.

The bodies which emit light are called luminous bodies. Example: sun, stars burning candle, etc

The bodies which does not emit light are called non-luminous bodies. Example moon, earth, blackboard.

2. Why is the moon not considered as a luminous body?

Moon is non-luminous body because it shines by reflecting the sunlight falling on it.

3. What is an incandescent body? Give example.

The bodies which emit light when heated to a very high temperature are called incandescent bodies. Example: electric bulb.

4. When does a shadow form?

Shadow is formed when light does not behind the opaque object kept in the path of light.

5. Draw a diagram to illustrate the formation of umbra and penumbra.

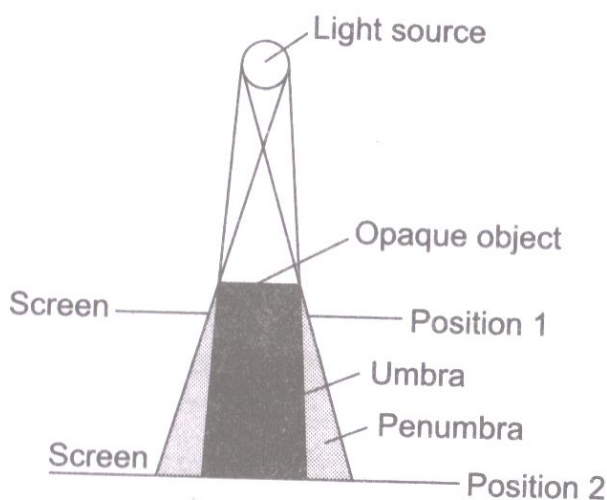

6. What are the essential conditions for the formation of shadow?

(1) There should be an opaque material.

(2) There should be a source of light and screen. The object must be placed in the path of light. Then only shadow is formed on the screen.

7. Define reflection of light.

When light rays after striking the smooth and shiny surface return to same medium, this phenomenon is called reflection of light.

8. Write difference between shadow and image.

Image	Shadow
(1) It is formed by intersection of reflected rays.	(1) Shadow is formed when light does not reach behind the object.
(2) Image is seen when reflected rays approach to observer's eyes	(2) No light enters the observer's eyes.
(3) Image gives more information such as colour, structure, etc.	(3) Shadow does not provide any such information.
(4) Image can be straight or inverted. Shadow	(4) Shadow is never inverted.

9. How will you convert a glass sheet into a translucent sheet?

There are following two methods to convert glass sheet into a translucent sheet:

- (i) By smearing a thin layer of oil on glass sheet.
- (ii) By covering a side of sheet by butter paper.

10. What is shadow? How does the colour of an opaque object affects the colour of the shadow?

A dark outline or patch formed by an opaque object that blocks light coming from a source of light is called shadow. The colour of an opaque object does not affect the colour of the shadow.

11. Write the differences between umbra and penumbra.

Umbra	Penumbra
(1) It is the darkest part of shadow.	(1) It is less dark part of shadow.
(2) No light reaches to this region.	(2) Light from some parts of the source reaches.
(3) It is central part of shadow.	(3) It is outer part of a shadow.

12. What do we need in order to see a shadow?

We need: (i) A source of light (ii) a screen (iii) an opaque object.

13. What do you mean by scattering of light?

When a beam of light falls on a rough surface it is turned back in different directions. It is called scattering of light.

14. A and B are facing the mirror and standing in such a way that A can see B and B can see A. Explain this phenomenon.

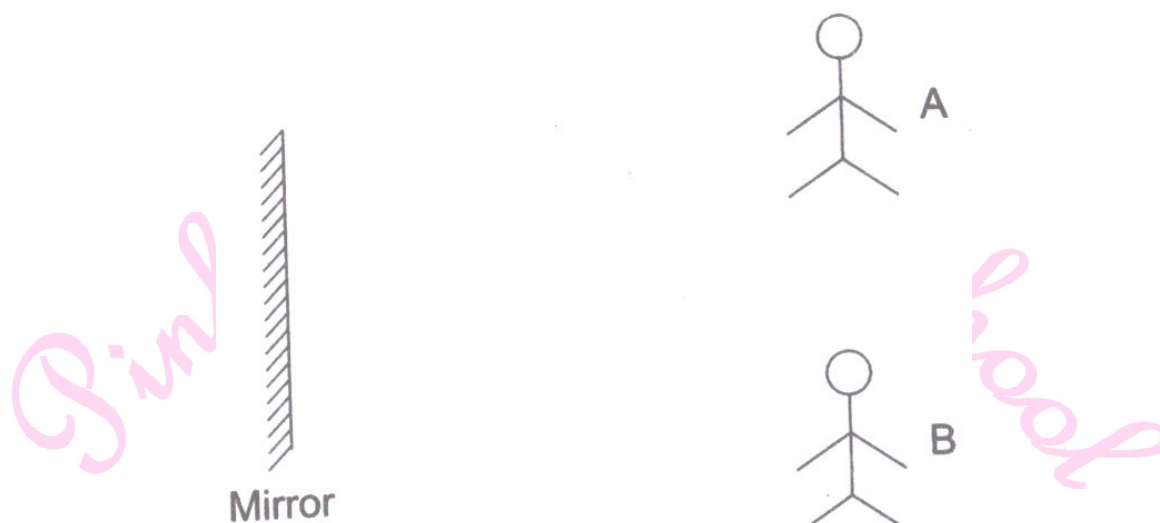

The light rays from A falls on the mirror and gets reflected and reaches B, the light from B falls on the mirror and reflects on A. The path of light is just reversed as shown in the figure.

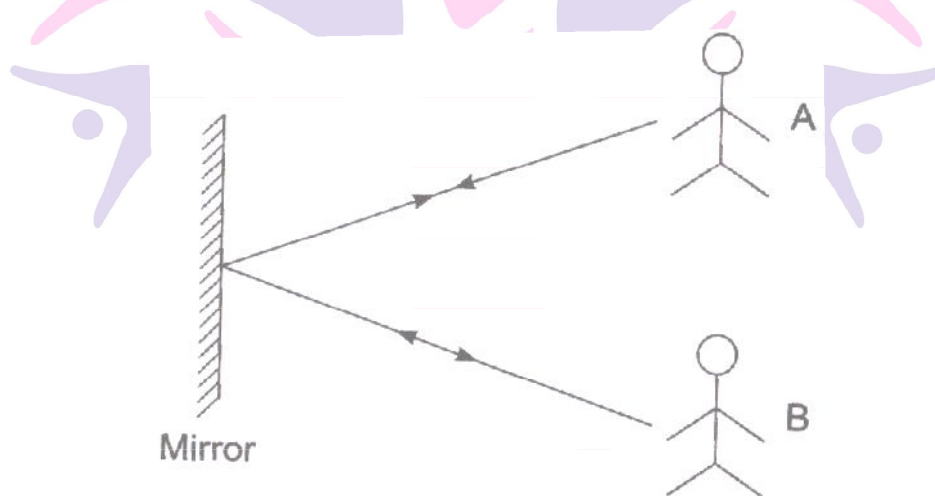

15. 'X' is 20 cm away from the mirror. If he moves few steps closer to the mirror what will happen to the image size in the mirror. Comment.

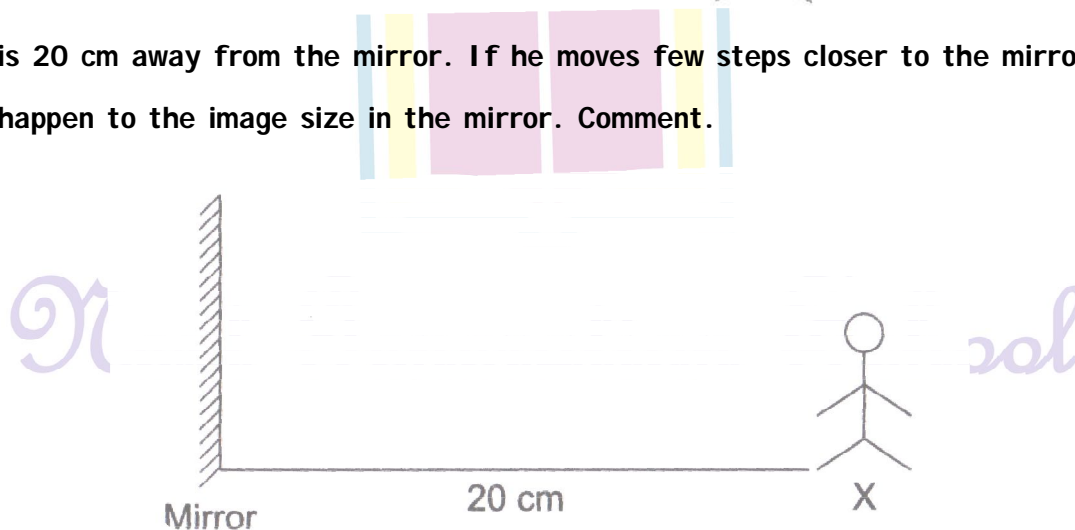

The size of the image will be same as the size of the object. Q16. Write the mirror image of 'SMART'?

TRAMƧ

17. Have you ever seen an ambulance? It is written in the form of mirror image on vehicles. Explain why it is done so and give the mirror image of AMBULANCE.

The mirror image of AMBULANCE is **ƎMƆAꞤAꞤUꞤMA** . It is written so on the vehicles for the people to see in their rear view mirrors, read it correctly and immediately give way to the vehicle as it carries patients who need urgent medication.

18. You have to cast the shadow of your pencil on the wall with the help of candle in a dark room. How can you obtain the shadow of same size, small size and big size of the same pencil?

(a) The shadow of the pencil will be small when the pencil is taken close to the wall and away from the candle,

(b) The shadow will be big in size when the pencil is taken closer to the candle.

(c) To get the same sized shadow as the pencil is, adjust the distance between the wall, pencil and candle at equal distances.

19. Moon appears bright at night. Is it a luminous or non-luminous body?

Moon is non-luminous body. It does not emit its own light. It reflects the sunlight that falls on it.

20. To see an object what do we need?

To see an object we need the following:

(i) source of light

(ii) an object

(iii) eyes

When a light emitting from luminous body falls on a non-luminous object and is reflected, this reflected light reaches our eyes which enables us to see that object.

Next Generation School

I. Long Answer Type Questions.

1. What is a shadow ? Explain a simple process for shadow formation.

Opaque objects do not allow light to pass through them. When an opaque object is placed in the path of light, then the light is obstructed by the object leading to the formation of a dark patch known as the shadow of that object, which can be taken on a screen placed behind it.

Shadow formation : To form a shadow, there must be (i) a light source (ii) a screen (iii) an opaque object placed between the light source and the screen. For shadow formation, we can follow the given steps.

Step 1 : Take an opaque object.

Step 2 : Throw light on it from a light source.

Step 3 : Put a screen behind the object. In this way, a shadow of an object can be obtained on the screen.

2. Explain about solar eclipse and lunar eclipse. Also, give the ray diagrams.

Solar Eclipse : When the sun, the earth and the moon come in a straight line with the moon in between the earth and the sun, then the shadow of the moon falls on the earth. This results in solar eclipse. Solar eclipse on a new moon day.

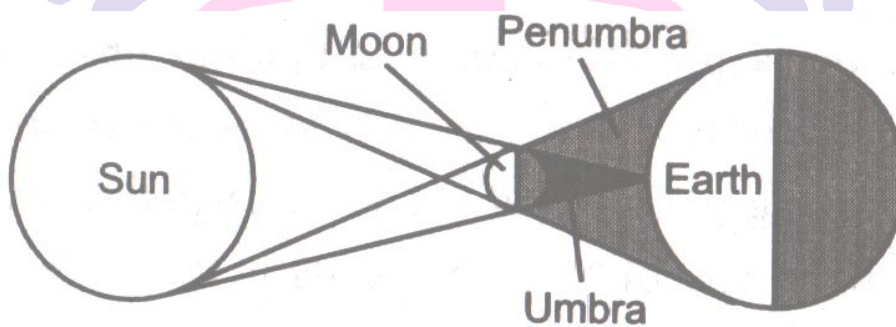

Lunar Eclipse: When the sun, the earth and the moon come in a straight line with the earth in between the moon and the sun then the shadow of the earth falls on the moon. This results in Lunar eclipse. Lunar eclipse takes place on a full moon day. The shadow consists of two parts. One part is completely dark part of the shadow, where light does not reach from the source of light and this part is known as umbra. Other part is not completely dark, where some light reaches from the source of light and this part is known as penumbra. Penumbra surrounds the umbra.

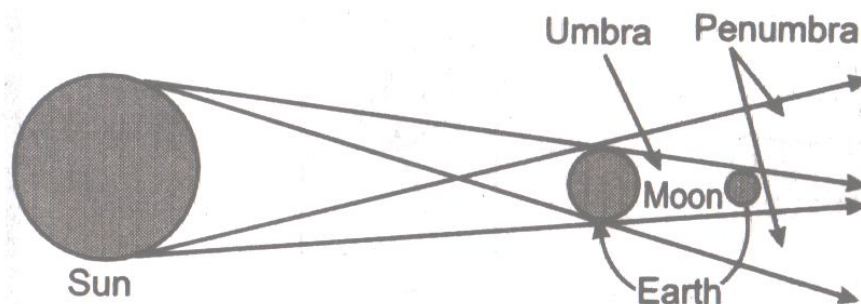

3. A football match is being played at night in stadium with flood light ON. You can see the shadow of a football kept at the ground but cannot see its shadow when it is kicked high in the air. Explain. [NCERT Exemplar]

We can see the shadow of a football kept at the ground in flood light because the ground of stadium acts as a screen for it but one cannot see its shadow when it is kicked high in the air because now ground will not act as screen due to more distance between ground and football. If we take an object away from the screen, the image becomes smaller and ultimately, it disappears from the screen.

4. A student had a ball, a screen and a torch in working condition. He tried to form a shadow of the ball on the screen by placing them at distance positions. Sometimes the shadow was not obtained. Explain. [NCERT Exemplar]

- i. The direction of the torch light is not towards screen.
- ii. The screen is away from the ball.
- iii. The torch is kept away from the ball.

5. A sheet of plywood, a piece of muslin cloth and that of a transparent glass, all of the same size and shape were placed at A one by one in the arrangement shown in Fig. Will the shadow be formed in each case. If yes, how will the shadow on the screen be different in each case? Give reasons for your answer.

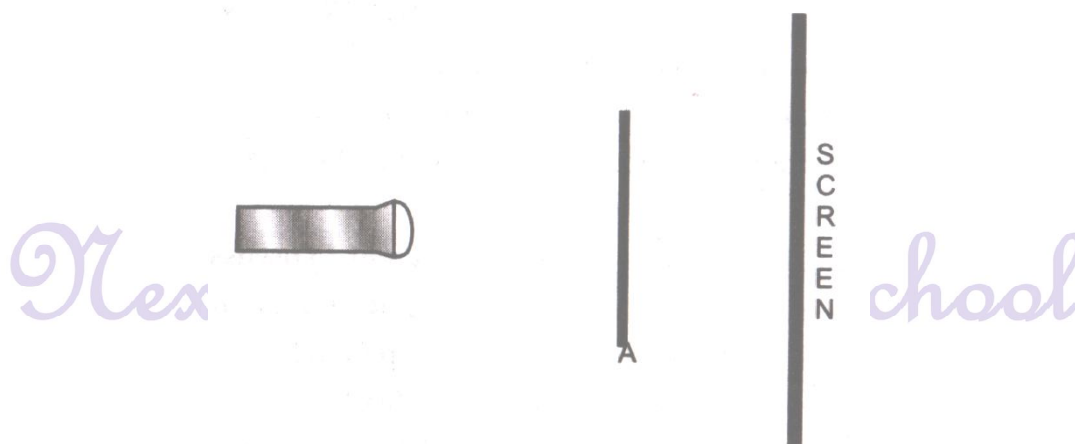

[NCERT Exemplar]

No, the shadow will not be formed in each case. The shadow will be formed in case of a sheet of plywood and a piece of muslin cloth, while, the shadow will not be formed in case of transparent glass, because light is allowed to pass through it.

A dark shadow will be formed by a piece of plywood because it is opaque and can block the path of light completely. A lighter shadow will be formed by a piece of muslin cloth as it allows light to pass through it partially.

II. Long Answer Type Questions.

1. What is reflection of light? Explain reflection of light with the help of an activity.

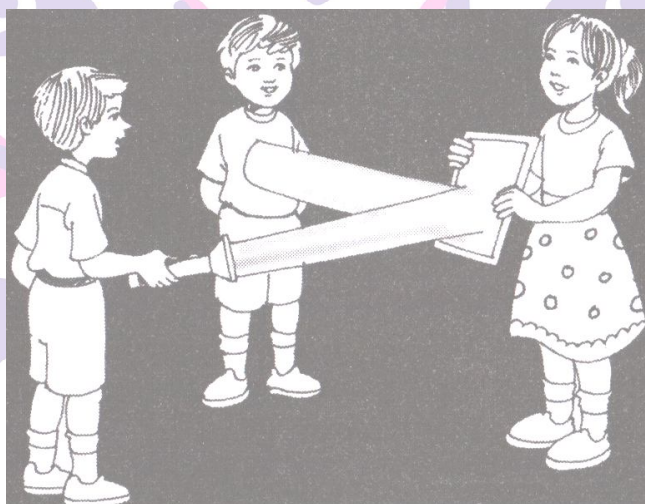

When light rays fall on a highly polished (e.g. mirror) smooth surface and return to the same medium, it is called reflection of light.

Activity to show reflection of light: This activity should be done at night or in a dark room. Ask your friend to hold a mirror in his hand at one corner of the room. Stand at another corner with a torch in your hand. Cover the glass of torch with your fingers and switch it on. There should be small gap between your fingers. Direct the beam of torch-light on to the mirror that your friend is holding. Adjust the direction of torch so that patch of light falls on your friend standing in the room. This activity shows the reflection of light also that light travels in straight line.

2. Explain the manner in which light travels with the help of an activity.

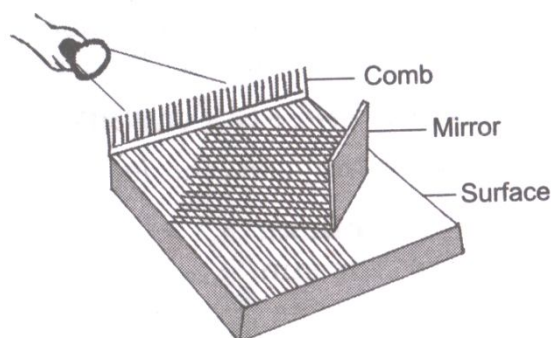

Take a comb and fix it on one side of a thermacol sheet. Fix a mirror on the other side as shown in figure. Spread a dark coloured sheet of paper between the mirror and the comb. Send a beam of light from a torch through the comb. You get a pattern of light similar to that shown in figure. This activity explains the manner in which light travels and gets reflected from a mirror.

3. Explain that light has the property of rectilinear propagation.

Take three pieces of cardboard. Place them on the top of one another and make a hole in the middle of each cardboard by using a thick nail. Erect these cards up on the table at a short distance away from each other. Take a candle which is of the same height as the holes in the cards. Light the candle and place it in front of the cards. We see that the light of candle is visible only when the holes on cards lie in a straight line. If we disturb them the light of candle disappears. This experiment shows that light propagates in a straight line.

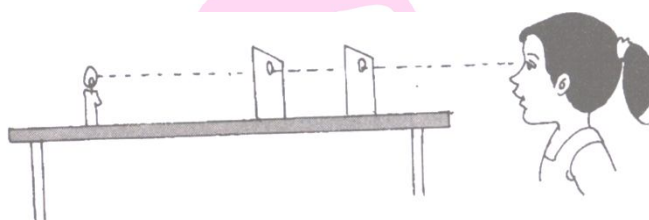

III. Long Answer Type Questions.

1. Distinguish between the following.

- Opaque objects and Transparent objects
- Solar eclipse and Lunar eclipse
- Luminous body and Non-luminous body
- Beam and Ray

a.

S.No	Opaque object	Transparent objects
i.	Object which do not allow any light to pass through them	Objects through which light can pass totally.
ii.	For example, book, brick, etc	For example, glass, air, etc.

b.

S.No	Solar eclipse	Lunar eclipse
i.	When the moon comes in between the sun and the earth, the earth darkens during the day. This is solar eclipse	When the earth is in between the sun and the moon, the moon cannot be seen. This is lunar eclipse.

c.

S.No	Luminous body	Non-luminous body
i.	Objects which emit their own light.	Object which do not emit their own light.
ii	For example, sun, stars, etc.	For example, moon, earth, etc.

d.

S.No	Beam	Ray
i.	A group of parallel rays is called beam	Path of light is called ray.
ii	It is represented by many arrows.	It is represented by an arrow.



Next Generation School

I. Higher Order Thinking Skills (HOT)

1. Can you think of creating a shape that would give a circular shadow if held in one way and a rectangular shadow if held in another way?

A cylinder

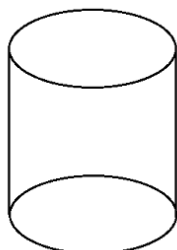

When light falls on the top surface of the cylinder, the shadow obtained is circular and when the light falls on the side of the cylinder, the shadow obtained is rectangular.

2. In a completely dark room, if you hold up a mirror in front of you, will you see a reflection of yourself in the mirror? [NCERT]

No image in the mirror will be seen in a dark room. This is because an image is formed by reflection of light rays. If there is no light, no image is formed.

II. Higher Order Thinking Skills (HOT)

1. Why is the shadow of an aeroplane flying high in the sky not seen on the ground?

The shadow of an aeroplane flying high in the sky is not seen on the ground because the ground will not act as screen for the aeroplane due to its high distance from the ground.

2. Rahul was studying at home in the evening. But due to improper power supply he could not study properly.

i. Why was Rahul able to study the print of book?

ii. What is the role of light?

i. Rahul was able to study the print of book due to light falling on the book which came to his eyes from a luminous object (i.e., tube light).

ii. The light allows us to see objects.

Skill Based Questions

1. Observe the picture given below. What does the mirror reflect?

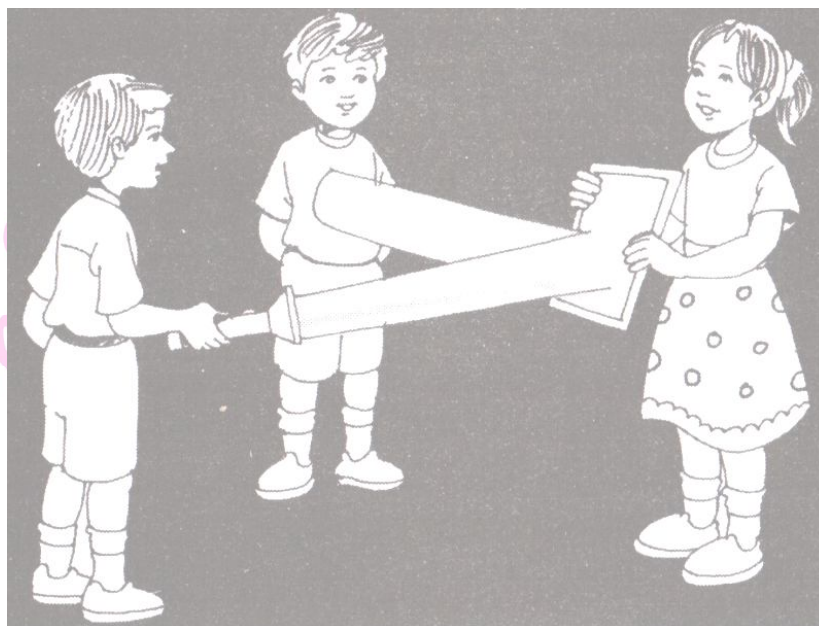

A mirror reflects a beam of light that falls on it.

2. Observe the diagram give below. What does the following activity depict?

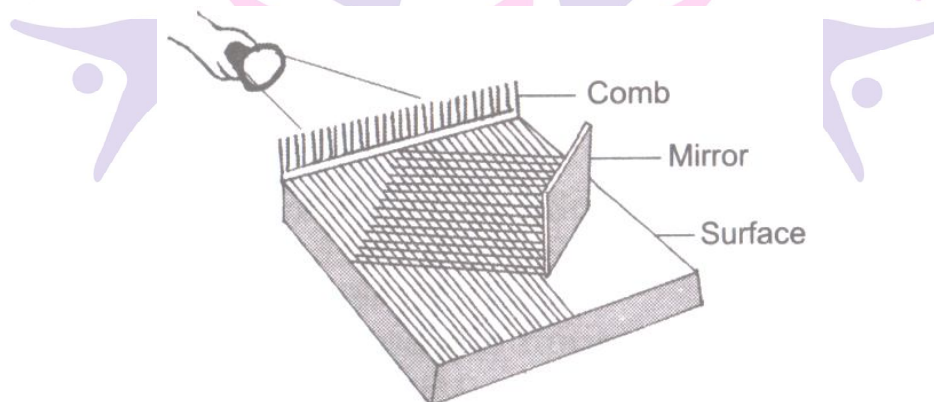

Light travels in straight line and gets reflected from a mirror.

3. Label 1 and 2 and write correct caption for picture. give its use.

1 - mirror, 2 - mirror, caption - Periscope.

It is used in submarines to see the objects above water.

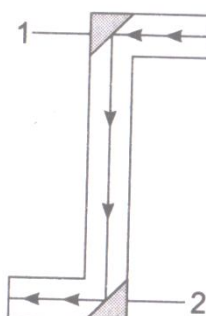

4. Draw a diagram of a sliding pin hole camera.

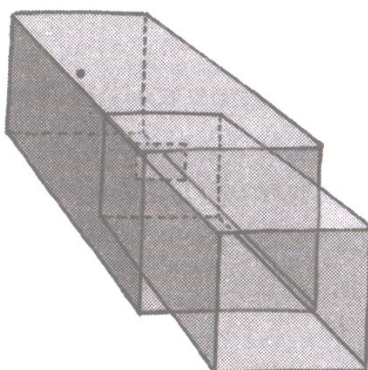

Know the Links

- www.byjus.com
- www.learncbse.in
- www.excellup.com
- www.studyrankers.com



Next Generation School